

ENGINEERING DRAWING
(Common to CE, ME and Ch.E)

Time: 3 hours

Max. Marks: 70

(Answer all five units, 05 X 14 = 70 Marks)

UNIT - I

- 1 (a) Construct an ellipse when the distance of the focus from the directrix is equal to 50 mm and eccentricity is $\frac{2}{3}$.
(b) Draw a hypocycloid when the radius of the directing circle is twice the radius of generating circle and radius of the generating circle is 35 mm.

OR

- 2 (a) Construct a rectangular hyperbola when a point p on it is at a distance of 18 mm and 34 mm from two asymptotes. Also draw a tangent to the curve at a point 20 mm from an asymptote.
(b) A thread of length 165 mm is wound round a circle of 40 mm diameter. Trace the path of end point of the thread.

UNIT - II

- 3 (a) The front view of a line, inclined at 30° to the V.P. is 65 mm long. Draw the projection of the line, when it is parallel to and 40 mm above the VP, its one end being 30 mm in front of the V.P.
(b) A regular pentagon of 25 mm side has one side on the ground. Its plane is inclined to H.P at 45° and perpendicular to V.P. Draw its projections.

OR

- 4 (a) A line PQ 75 mm long has its end P in both HP and VP. It is inclined at an angle of 30° to HP and 45° to VP. Draw projections of the line.
(b) A rectangular plane of 60 mm \times 40 mm is resting on shorter edge on the ground and inclined at 45° to V.P. The plane surface is inclined at 30° to H.P. Draw its projections.

UNIT - III

- 5 (a) Draw the projections of a hexagonal prism side of base 25 mm and height 60 mm resting with its base on H.P. such that one of its rectangular faces is parallel to V.P.
(b) A cylinder of base diameter 50 mm and height 60 mm rests on its base on HP. It is cut by a plane perpendicular to VP and inclined at 45° to HP. The cutting plane meets the axis at a distance 15 mm from the top to the base. Draw the sectional plan and true shape of section.

OR

- 6 (a) A square prism base 40 mm side and height 65 mm, has its axis inclined 45° to ground and has an edge of its base on the ground and inclined at 30° to the V.P. Draw its projections.
(b) Hexagonal pyramid side of base 25 mm and axis 50 mm long rests with one of the corners of its base on H.P. Its axis is inclined at 30° to H.P. and 45° to V.P. Draw its projections.

Contd. in page 2

UNIT - IV

- 7 Two views of a casting are shown below. Draw the isometric view of the casting (dimensions are in mm).

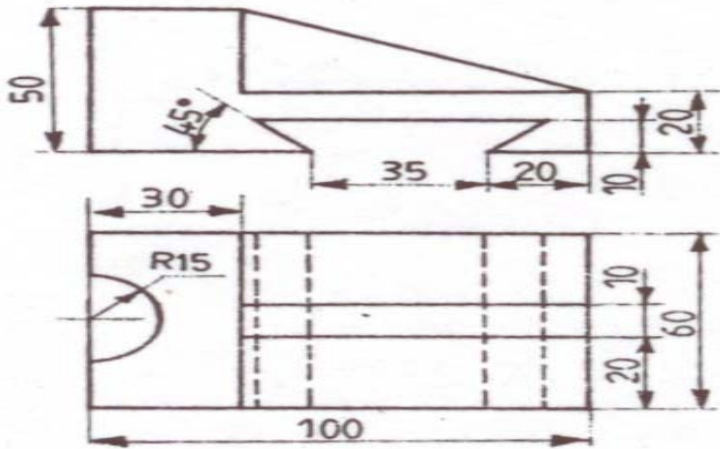

OR

- 8 Draw the front view, top view and right side view of the object shown below (dimensions in mm).

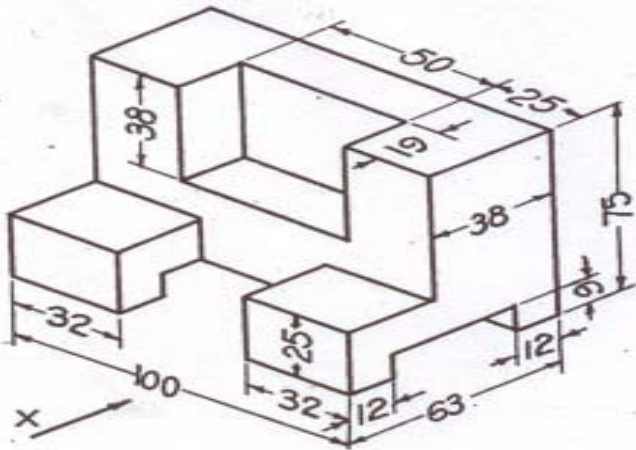

UNIT - V

- 9 A cylinder of 60 mm diameter and axis 80 mm long is standing on its base on HP. A horizontal rectangular hole of 35 mm x 25 mm sides is cut through the cylinder. Axis of the hole is parallel to VP. The axes of both cylinder and hole intersect at right angles and bisect each other. Draw the projections and show the curves of intersection.
- OR
- 10 A square plane with a 50 mm side lies on the GP with the edge nearer to the observer lying in the PP. The station point is 40 mm in front of PP, 50 mm above GP and lies in a CP which is 40 mm towards right of the center of the object. Draw its perspective view.
